

# DATASHEET

## Thermal Protector SR6

### Type series R6

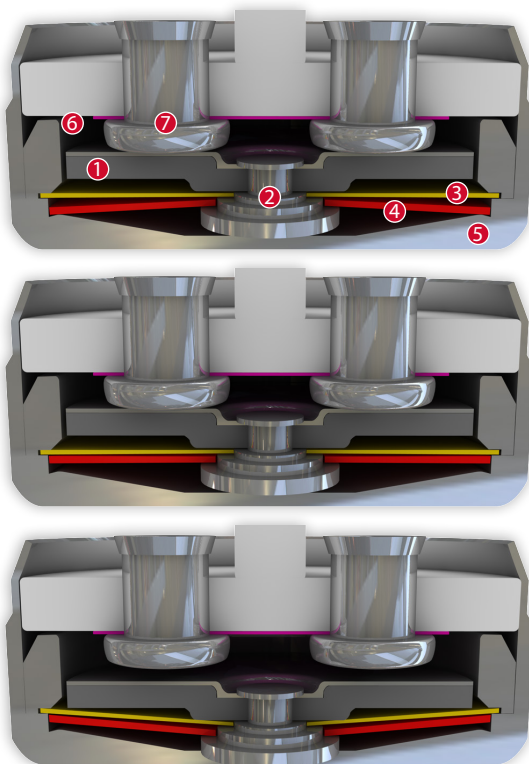

### Construction and function

Switchgear consisting of a mobile and circumferential contact bridge (1), a contact bearing pin (2), a spring snap-in disc (3) and a bimetallic disc (4) which is riveted into one another, undetachable and fixed in a positive lock and self-aligning between a non-conductive floor of a housing (5) and an insulating ceramic bearing (6) with two integrated stationary contacts (7) as electrodes. At the same time, the switchgear is supported by the spring snap-in disc (3) with the contact bridge (1) acting as a transfer element for electric current which is held between a supporting collar and a circumferential ring. As such, the bimetallic disc (4) underlying it, that is also stuck out from the contact bearing pin (2), can continuously work (exposed) by mechanical loads without the contact pressure defined by the spring snap-in disc (3) diminishing. As soon as the bimetallic disc (4) reaches its rated switching temperature, it effectively springs against the throw force of the spring snap-in disc (3) into its inverted position. The contacts (7) are abruptly opened. The resistance ceramic (6) switched in parallel now sustains the operating voltage and deploys a defined electrical heating output on the switchgear regardless of the ambient temperature and permanently sustains it above its springback temperature so that the switchgear cannot reset back. The contacts remain open. The Thermal protectors can only cool down again and switch to the original closed state when the external operating voltage is no longer applied and/or disconnection from the mains.



### Features:

|                                 |   |
|---------------------------------|---|
| Quick response sensitivity      | featured by the brass housing and small protector mass  |
| Excellent long term performance | due to fine silver contacts. Reproducible switching temperature values due to tempered, electrically and mechanically unstressed bimetal disc. Minimal contact burn |
| Instantaneous switching         | with always constant contact pressure up to the nominal switching point, resulting in low contact stress  |
| Very short bounce times         | < 1 ms  |
| Temperature resistance          | by use of high temperature resistant materials and components   |

SR6

Type: Normally closed; does not reset automatically; voltage applied; with connector cables; with epoxy; insulation: Mylar®-Nomex®

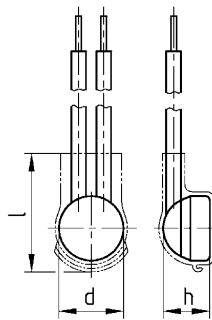

|                                |             |
|--------------------------------|-------------|
| Installation height h          | from 6,7 mm |
| Diameter d                     | 9,4 mm      |
| Length of the insulation cap l | 17,0 mm     |

|  |  |         |
|--|--|---------|
| Nominal switching temperature (NST) in 5 °C increments   | 60 °C - 180 °C                         |         |
| Tolerance NST ≤ 140 °C   | ±5 K                                   |         |
| Tolerance NST > 140 °C   | ±10 K                                  |         |
| Reverse switch temperature (RST) below NST (defined RST is possible at the customer's request) | UL                                     | ≥ 35 °C |
|  | VDE                                    | ≥ 35 °C |
| Installation height  | from 6,7 mm                            |         |
| Diameter   | 9,4 mm                                 |         |
| Length of the insulation cap   | 17,0 mm                                |         |
| Resistance to impregnation *   | suitable                               |         |
| Suitable for installation in protection class  | I + II                                 |         |
| Pressure resistance to the switch housing *  | 600 N                                  |         |
| Standard connection  | Lead wire 0,75 mm <sup>2</sup> / AWG18 |         |
| Available approvals (please state)   | IEC; ENEC; VDE; UL; CSA; CQC           |         |
| Operational voltage range AC/DC  | up until 250 V                         |         |
| Rated voltage AC   | 120 V / 230 V (VDE) 250 V (UL)         |         |
| Rated current AC cos φ = 1.0/cycles  | 10,0 A / 1.000                         |         |
| Rated current AC cos φ = 0.6/cycles  | 6,3 A / 1.000                          |         |
| Max. switching current AC cos φ = 1.0/cycles   | 25,0 A / 1.000                         |         |
| High voltage resistance  | 2,0 kV                                 |         |
| Total bounce time  | < 1 ms                                 |         |
| Contact resistance (according to MIL-STD. R5757)   | ≤ 50 mΩ                                |         |
| Vibration resistance at 10 ... 60 Hz   | 100 m/s <sup>2</sup>                   |         |

Current sensitivity characteristic at I<sub>nom</sub>:

dependent of...

- Thermal coupling
- Application area
- Built-in conditions
- Outer influences
- Wiring length / wiring diameter

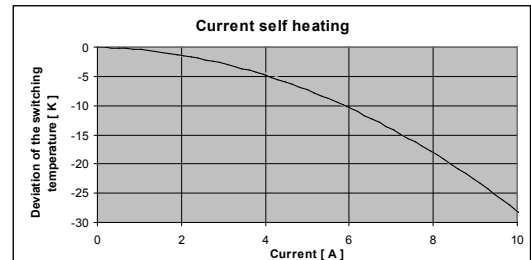

Ordering example:

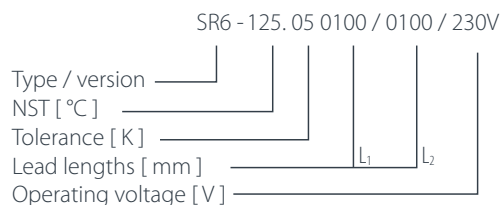

Marking example:



More varieties of the type series R6:

- CR6 – voltage applied; with connector cables; with epoxy; without insulation

[www.thermik.de/data/CR6](http://www.thermik.de/data/CR6)

\*In accordance with the Thermik test - Specifications relating to part applications (on the part of the buyer) which deviate from our standards are not checked for their capacity to support an application and/or conformity with standards. The responsibility for testing the suitability of Thermik products for such applications falls upon the user. Slight deviations are possible in terms of dimensions/ values, depending on the embodiment of the product. We reserve the right to make technical changes in the course of further development. - Details concerning certain data, measurement methods, applications, approvals, etc. can be supplied upon request.